

THE INFORMATION CONTAINED IN THIS DRAWING IS THE SOLE PROPERTY OF GATOR DOCK & MARINE, LLC. ANY REPRODUCTION IN PART OR AS A WHOLE WITHOUT THE WRITTEN PERMISSION OF GATOR DOCK & MARINE, LLC IS PROHIBITED.

RECORD OF REVISIONS

No.	DATE	DESCRIPTION:
0	--/--	--
1	--/--	--
2	--/--	--

PROJECT NAME:

CUSTOMER NAME:

CUSTOMER ADDRESS:

PROJECT LOCATION:

CMI ORDER NO.:

CUSTOMER PO NO.:

	NAME	DATE
DRAWN BY:	ERJ	--/--
CHECKED BY:	JCP	--/--

DRAWING NO.:

TOP DECKED PONTOON FLOATING DOCK DETAILS

Physical properties are defined by ASTM testing standards. The Aluminum Association Design Manual, and/or standard engineering practice. The values shown are nominal and may vary. The information found in this document is believed to be true and accurate. No warranties of any kind are made as to the suitability of any CMI product for particular applications or the results obtained there from. ShoreGuard, C-Loc, TimberGuard, GeoGuard, Dura Dock, Shore-All, and Gator Gates are registered trademarks of Crane Materials International. ArmorWare, Ultra Composite, GatorDocks, and CMI Waterfront Solutions are trademarks of Crane Materials International. United States and International Patent numbers 5,145,287; 5,881,508; 6,000,883; 6,033,155; 6,053,666; D420,154; 4,674,921; 4,690,588; 5,292,208; 6,575,667; 7,059,807; 7,056,066; 7,026,539; 1,245,061; Other patents pending. © 2008 Crane Materials International. All Rights Reserved.

Authorized By:

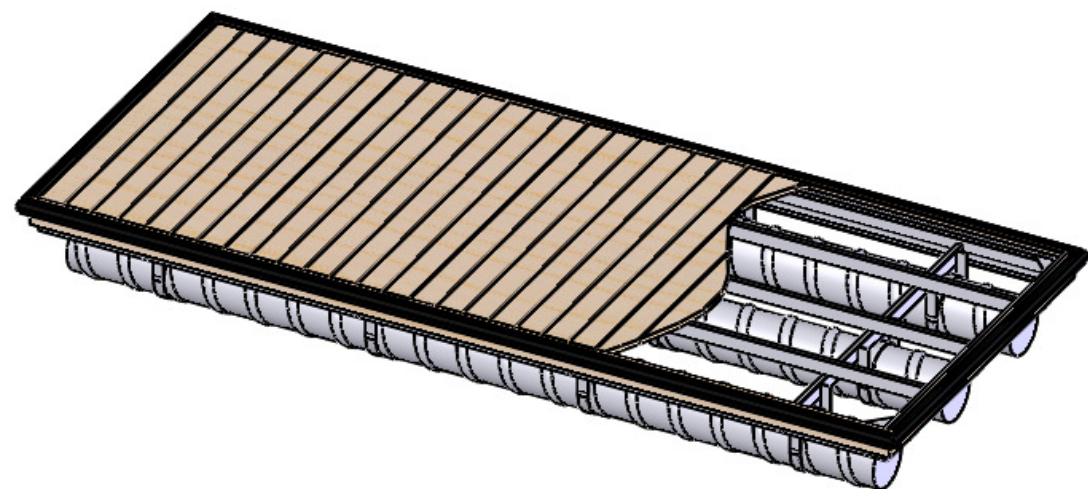

ISOMETRIC VIEW OF TOP DECKED PONTOON FLOATING DOCK

SCALE: NTS

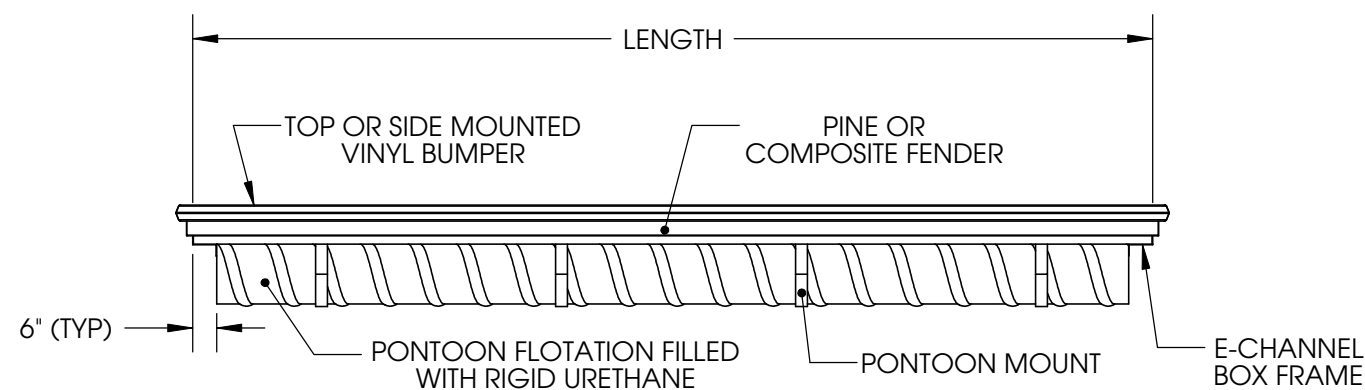

ELEVATION VIEW OF TOP DECKED PONTOON FLOATING DOCK

SCALE: NTS

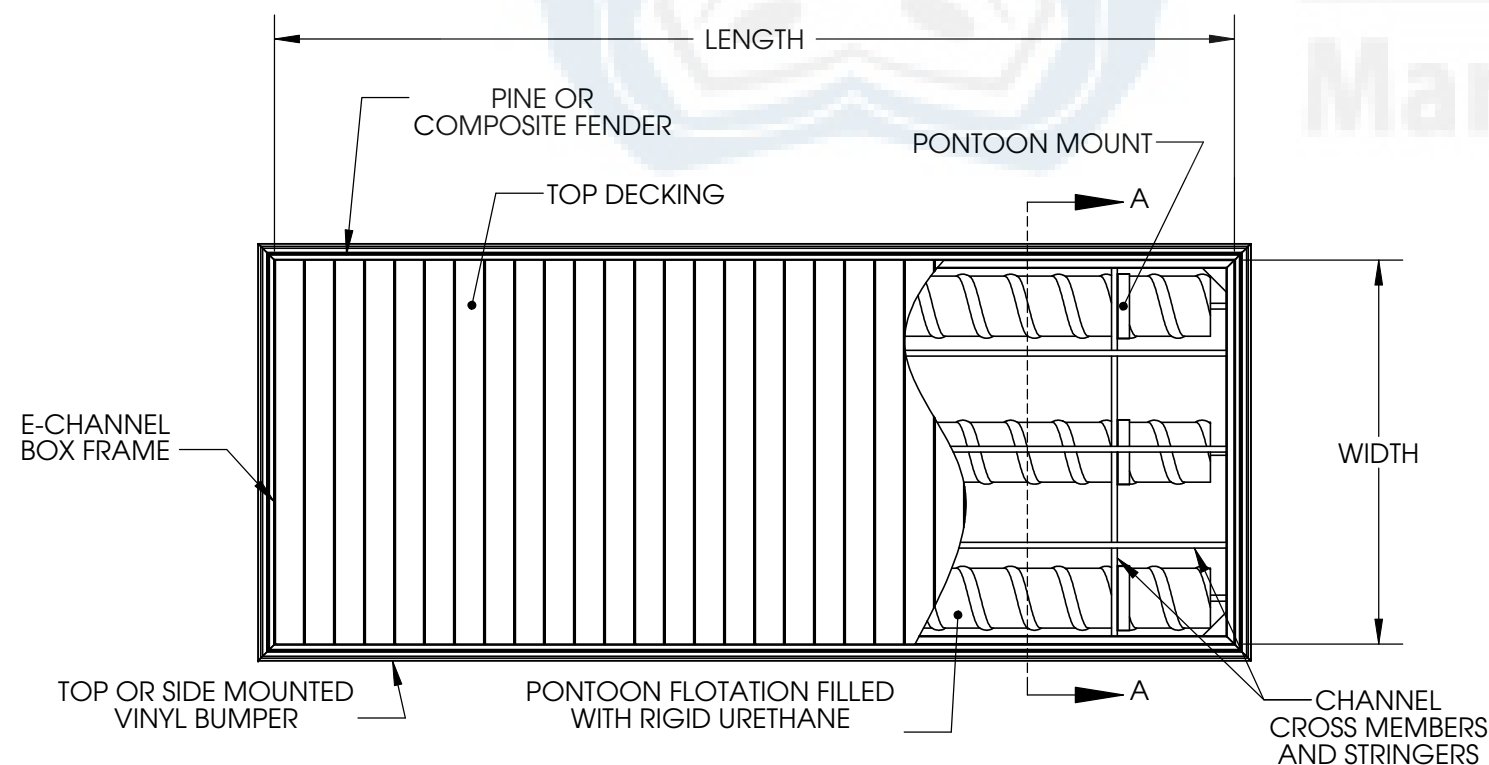

PLAN VIEW OF TOP DECKED PONTOON FLOATING DOCK

SCALE: NTS

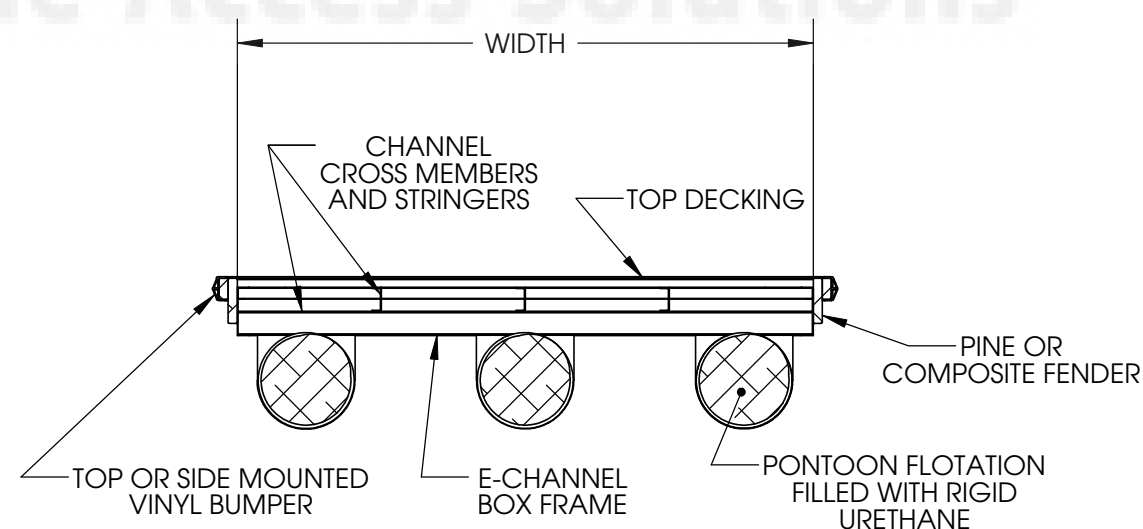

SECTION A-A

SCALE: NTS

GATOR DOCK™
Marine Access Solutions

THE INFORMATION CONTAINED IN THIS DRAWING IS THE SOLE PROPERTY OF GATOR DOCK & MARINE, LLC. ANY REPRODUCTION IN PART OR AS A WHOLE WITHOUT THE WRITTEN PERMISSION OF GATOR DOCK & MARINE, LLC IS PROHIBITED.

RECORD OF REVISIONS

No.	DATE	DESCRIPTION:
0	--/--/--	---
1	--/--/--	---
2	--/--/--	---

PROJECT NAME:

CUSTOMER NAME:

CUSTOMER ADDRESS:

PROJECT LOCATION:

CMI ORDER NO.:

CUSTOMER PO NO.:

	NAME	DATE
DRAWN BY:	ERJ	--/--/--
CHECKED BY:	JCP	--/--/--

DRAWING NO.:

FLOATING DOCK COMPONENTS

Physical properties are defined by ASTM testing standards. The Aluminum Association Design Manual, and/or standard engineering practice. The values shown are nominal and may vary. The information found in this document is believed to be true and accurate. No warranties of any kind are made as to the suitability of any CMI product for particular applications or the results obtained there from. ShoreGuard, C-Loc, TimberGuard, GeoGuard, Dura Dock, Shore-All, and Gator Gates are registered trademarks of Crane Materials International. ArmorWare, Ultra Composite, GatorDocks, and CMI Waterfront Solutions are trademarks of Crane Materials International. United States and International Patent numbers 5,145,287; 5,881,508; 6,000,883; 6,033,155; 6,053,666; D420,154; 4,674,921; 4,690,588; 5,292,208; 6,575,567; 7,059,807; 7,056,066; 7,026,539; 1,245,061; Other patents pending. © 2008 Crane Materials International. All Rights Reserved.

Authorized By:

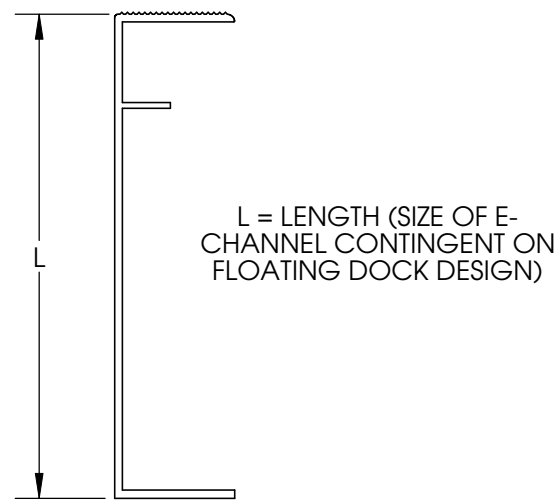

E-CHANNEL DETAIL

SCALE: NTS

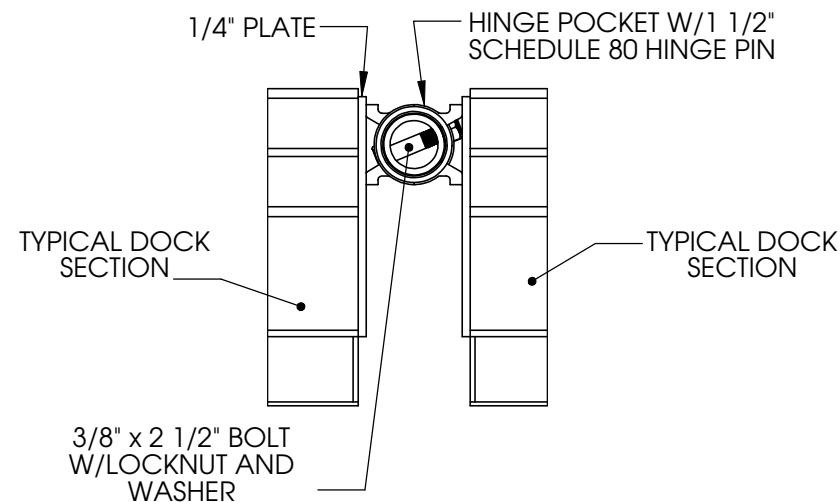

HINGED DOCK CONNECTION

SCALE: NTS

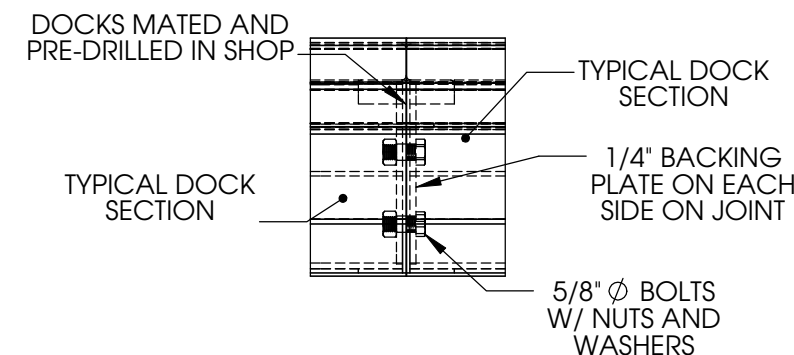

REINFORCED BOLTED DOCK CONNECTION

SCALE: NTS

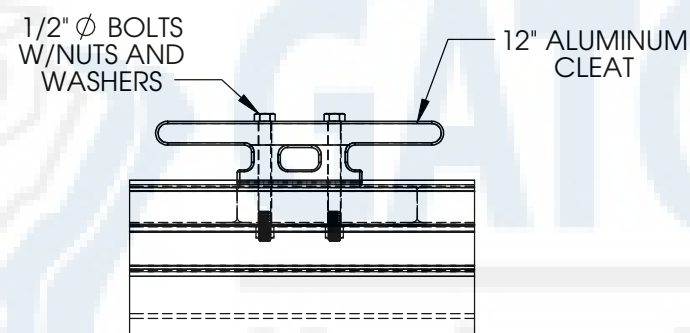

CLEAT DETAIL

SCALE: NTS

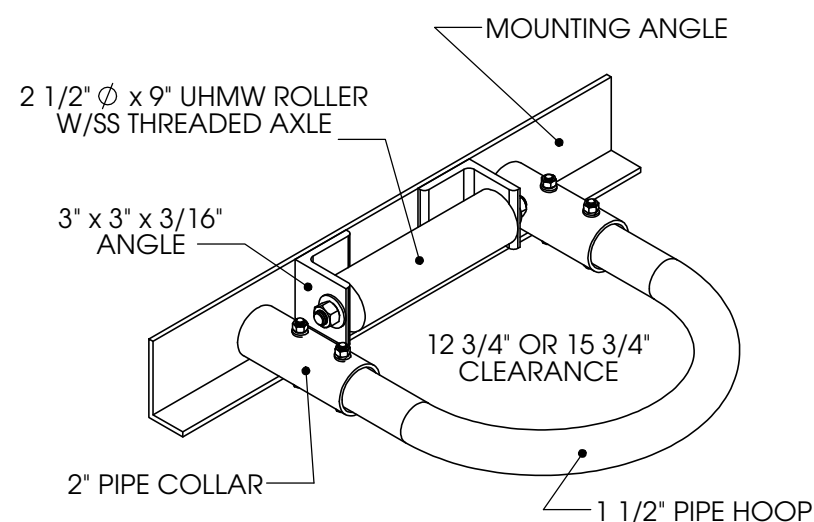

1-ROLLER EXTERNAL PILE GUIDE

SCALE: NTS

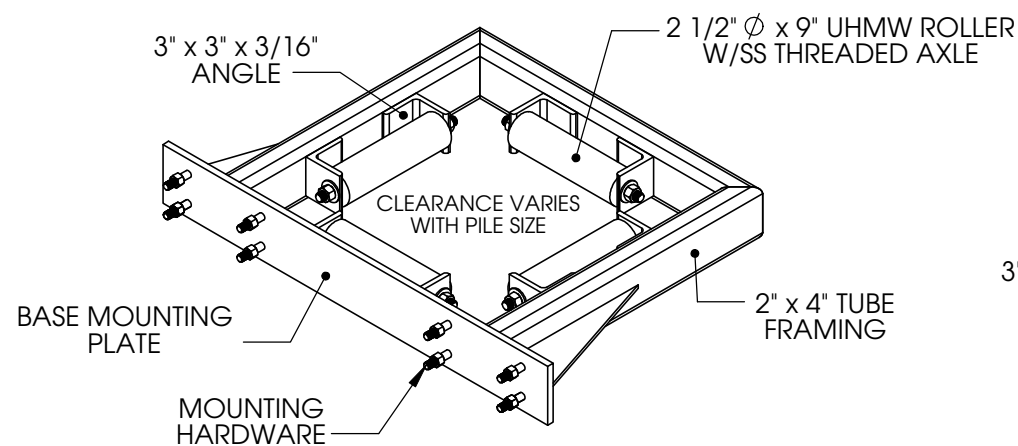

4-ROLLER EXTERNAL PILE GUIDE

SCALE: NTS

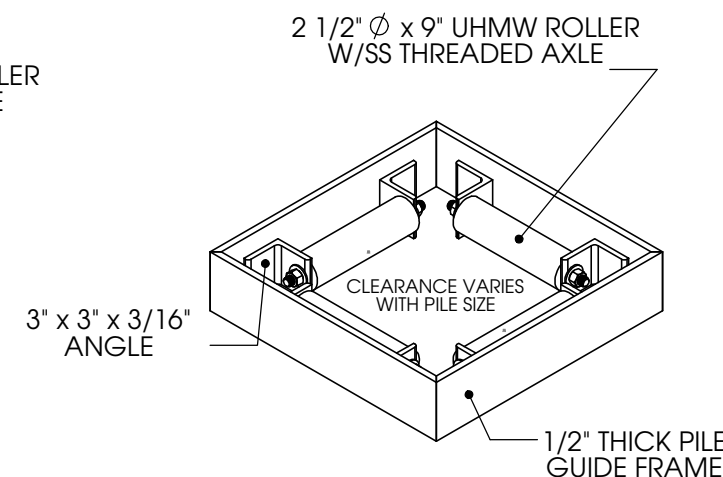

4-ROLLER INTERNAL PILE GUIDE

SCALE: NTS